

IKANO

Bostad

TOMTBLAD

BRF. STROSA







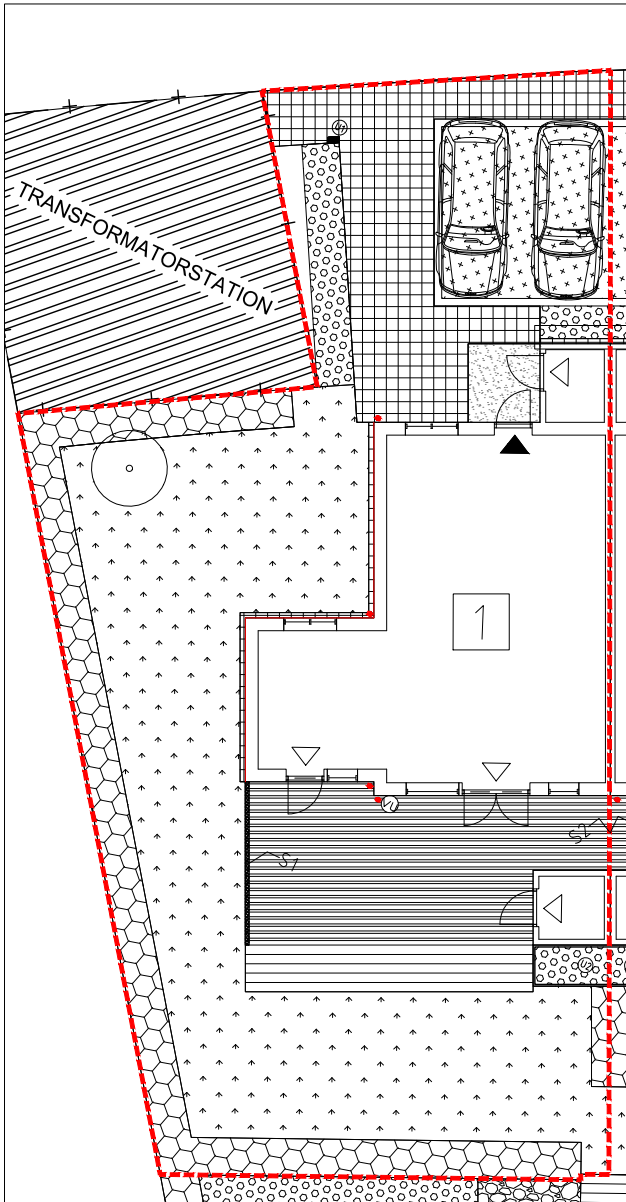









HUS 1

TOMTAREA 363 M²

SKALA 1:200 (A4)



FÖRKLARINGAR I FÖRKOMMANDE FALL

-  GRÄNS UPPLÄTEN MARK MED NYTTJÄNDERÄTT
-  BETONGPLATTOR
-  STENMJÖLSYTA
-  HÄCKPLANTERING
-  BUSKPLANTERING
-  GRÄSMATTA
-  TRÄTRALL
-  MAKADAM
-  BETONGYTA
-  TRAPPA
-  S1 - STAKET UTFÖRANDE ENLIGT A, H: ca 1100mm
S2 - PLANK UTFÖRANDE ENLIGT A, H: ca 1800mm
S3 - SPALJÉ MINST 50% GENEMSIKTIG
-  STUPRÖR
-  VATTENUTKASTARE
-  TRÄD
-  BREVLÅDA
-  UPPHÖJD PLANTERINGSLÅDA AV CORTEN



YTANGIVELSER ÄR PRELIMINÄRA - TOMTYTOR ÄR AVRUNDADE TILL HELTAL
ORIGINALFORMAT A4 SKALA 1:200
UPPRÄTTAD AV LANDSKAPSPROJEKTÖREN SYD AB - 2022-01-27
EVENTUELLA BRUNNAR INOM UPPLÄTEN MARK SKA VARA TILLGÄNGLIGA
FÖR FÖRENINGEN ATT KOMMA ÅT
MED RESERVATION FÖR EVENTUELLA FÖRÄNDRINGAR